

INSTALLATION INSTRUCTIONS

Thank you for purchasing a quality Hellwig Product.

PLEASE READ THIS INSTRUCTION SHEET COMPLETELY BEFORE STARTING YOUR INSTALLATION

IMPORTANT NOTES

DO NOT INSTALL THIS UNIT ON CAB AND CHASSIS TRUCKS. THIS UNIT WILL INTERFERE WITH THE REAR TIRES ON CAB AND CHASSIS TRUCKS CAUSING DAMAGE TO THE AIR SPRING OR TIRES, OR TO BOTH. THIS KIT IS DESIGNED FOR USE ON PICKUP TRUCKS ONLY

DO NOT ATTEMPT ANY MODIFICATIONS TO THE VEHICLE OTHER THAN THOSE OUTLINED IN THIS INSTRUCTION AND WARNING SHEET. IF ANY INTERFERENCE WITH THE GAS TANK , FUEL OR BRAKE LINES, EXHAUST PIPE ETC.. STOP YOUR INSTALLATION AND CALL HELLWIG PRODUCTS FOR TECHNICAL HELP OR INSTRUCTIONS.

NEVER LOAD THE VEHICLE THIS UNIT IS INSTALLED ON BEYOND THE VEHICLES MANUFACTURER'S MAXIMUM GROSS WEIGHT RATING.

TORQUE TABLE BOLT SIZE:

3/8" = 20-30 ft. lbs. – 7/16" = 35-45 ft. lbs.
 1/2" = 50-70 ft. lbs. – 9/16" = 70-90 ft. lbs.-5/8"=120 ft. lbs.

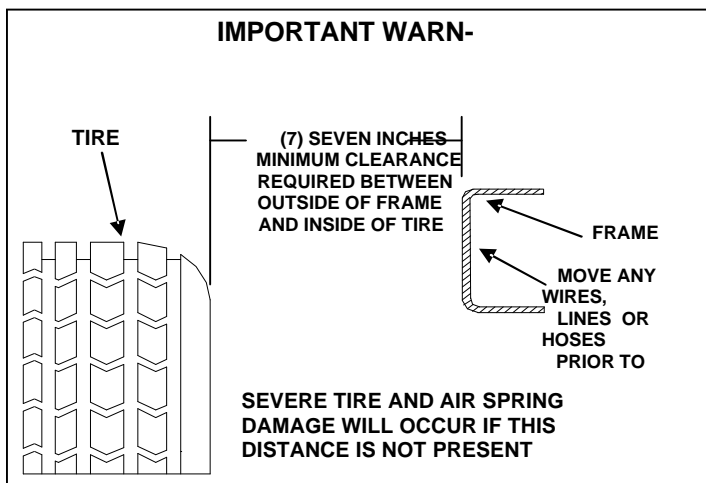

FIG # 1 TIRE TO WHEEL CLEARANCE

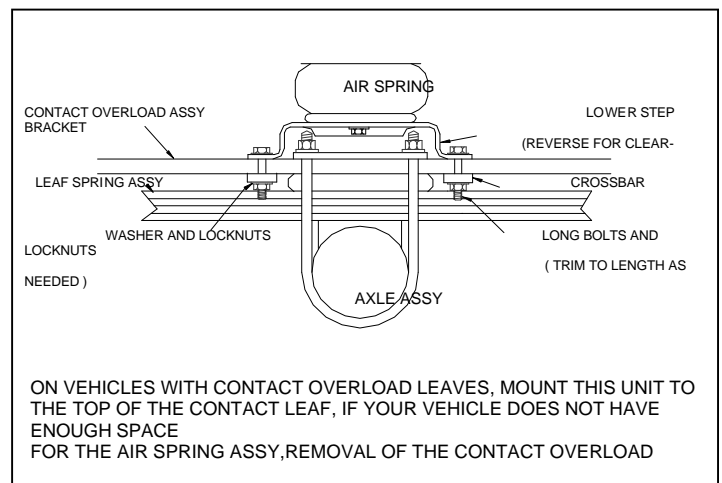

FIG # 2 CONTACT OVERLAOD INSTALLATION



559-734-7451 800-367-5480 FAX 559-734-7460

NOTE: THIS UNIT IS DESIGNED TO MOUNT TO THE SIDE OF THE FRAME AND TO THE LEAF SPRING ABOVE THE AXLE. DRILLING HOLES IN THE SIDE OF THE FRAME WILL BE NECESSARY. IT WILL BE NECESSARY TO REMOVE THE TIRES, SUPPORT THE VEHICLE BY THE AXLE WITH SAFETY STANDS AND BLOCK THE FRONT TIRES.

IMPORTANT: BEFORE BEGINNING THE INSTALLATION, CHECK TO BE SURE THERE IS ENOUGH CLEARANCE BETWEEN THE FRAME AND THE TIRE FOR THIS ASSEMBLY. 1994 AND NEWER DODGE 4-WHEEL DRIVE PICKUPS MINIMUM CLEARANCE DISTANCE IS (7) INCHES. SEE DIAGRAM DETAILING FENDER WELL MODIFICATIONS NECESSARY FOR THIS INSTALLATION. (SEE FIG # 7)

1. This unit is designed to be fully adjustable, the upper frame brackets and top air spring plate are made up from three different brackets. Attach the air spring to the top plate with the **3/8"** lock-nuts provided. Be sure the air line fitting hole aligns with the large hole on the plate, the bent lips on the upper plate go upwards away from the air spring. Tighten to **20 ft. lbs. max.** Install the air line fitting into the large hole in the top of the air spring. Tighten completely so that some of the red sealant is down inside the threaded hole. Align the hose port on the fitting to point towards the expected air line route. Be careful not to damage the hose nut or the inner hose sleeve when tightening the fittings. (**SEE FIG # 3 OR # 5**)
2. Attach the lower step bracket to the bottom of the air spring. Use the small bolt and lock washer provided. A variety of slots are provided to assure proper air spring alignment. Tighten to be snug. **20 ft lbs. max.** Reverse direction or switch holes or positions as to best fit your particular vehicle. (**SEE FIG # 3 OR # 5**)
3. Place the assembly onto the leaf springs above the axle. The frame mount brackets are reversible above or below the top plate, however, there is a right and a left side. The left side below the plate is the right side above the plate. Position the mount brackets to attach to the top of the upper air spring plate and so the frame mounting holes are against the side of the frame rail. Attach the frame mount brackets to the upper plate with the shortest **3/8"** bolts provided. Be sure to place the heads of the bolts on the air spring side of the bracket. Adjust the frame brackets to compensate for any contours on your particular frame. Snug these bolts, **DO NOT TIGHTEN.** (**SEE FIG # 4 OR # 6**)
4. Adjust the upper brackets on the frame so the air spring is as straight up and down as possible. Set the air spring to be between **5** and **6-1/2** inches between the brackets. The air springs come shipped at approximately **6"**, this is a good set up height. Use the **(4)** extra crossbars provided as spacers to elevate one end of the step brackets on the leaf springs to make the assembly as level as possible. (**SEE FIG # 3**)
5. With the air spring straight and at the desired setup height, use the holes in the frame brackets and mark the locations to drill the holes, make the mark in the center of the slots to allow for adjustment. **Be sure to double check all dimensions.** (**SEE FIG # 3 OR # 5**)
6. Being sure to move any lines or wires inside the frame to avoid damaging with the drill. Drill the **(4)** mount holes with a **7/16"** drill bit. Repeat this process for the other side.
7. Place the remaining short **3/8"** bolts provided through the frame brackets and frame so the threads are under the vehicle. Place the flat plates inside the frame on the bolts and attach with the locknuts provided. Tighten only to be snug. Be sure not to pinch any lines, hoses or wires inside the frame with the flat plates. (**SEE FIGURE # 4 OR # 6**)



559-734-7451 800-367-5480 FAX 559-734-7460

8. Move the lower step bracket front to rear and side to side to adjust the air spring to be as straight as possible. Once the upper bracket location is established, torque the frame brackets to the specified rate. Use the extra crossbars provided as shims between the lower step bracket and the leaf springs to help level the step bracket to the frame bracket as needed. Be sure to run the long bolts through all the holes in the brackets and crossbars to secure completely. (**SEE FIG # 3 OR # 5**)
9. Place the long bolts into the slots in the step bracket so the threads hang down below the leaf springs. Attach to the leaf springs with the crossbars, washers and locknuts provided. Make necessary adjustments and torque. Double check all nuts and bolts to assure proper torque. **Do not add any air pressure to the system without double checking torque.** At this point all of the air spring mounting hardware should be torqued.
10. Unroll the air hose and cut into (2) even lengths, roll the ends of the hose on a hard surface to make the ends as round as possible.
11. Install one end of the hose into the elbow at the top of the air spring. **See the hose end diagram for details on the particular style of hose connections used.** (**SEE FIG # 8**)
12. Route the air hose to the desired fill area, this is usually the rear bumper or a minimum 5/16" hole in the frame. If an on board compressor is being used, follow the hose route instructions included with the compressor. Route the air hose inside the frame and tie to the frame with the plastic tie straps provided. Keep the air hose away from the exhaust and the shocks or other areas where the hose can rub or become chafed on any sharp objects.
13. If needed slide the black hose insulators onto the hose and position near the exhaust. **DO NOT** allow the insulator to contact the exhaust, minimum 1-1/2" clearance. Use one inflator valve for each air spring.
14. Inflate the air spring to approximately **40 PSI** and check for clearance on the frame brackets, tires, brake lines etc.. Check the air spring for proper alignment from top to bottom between the brackets. Deflate and make adjustments as needed. With the system inflated, squirt soapy water over all of the hose and fitting connections to check for leaks. Deflate the system and repair as needed. RETEST
15. **KEEP A MINIMUM OF 10 PSI IN THE SYSTEM AT ALL TIMES, YOU MAY SELECT THE IDEAL INFLATION PRESSURE FOR RIDE CONFORT AND LOAD CARRYING UP TO 100 PSI MAXIMUM.**

ATTENTION INSTALLER: BE SURE CUSTOMER RECEIVES THIS INSTRUCTION SHEET, WARNING CARDS AND THE WARRANTY FORM.

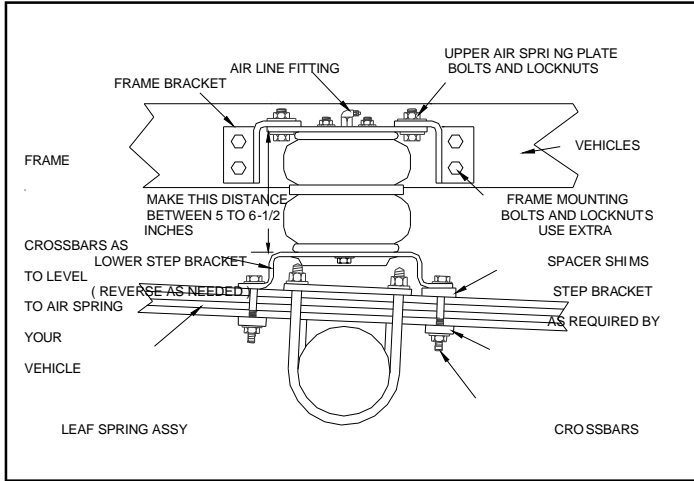

**FIG # 3 STANDARD MOUNTING STYLE
VIEW FROM TIRE SIDE**

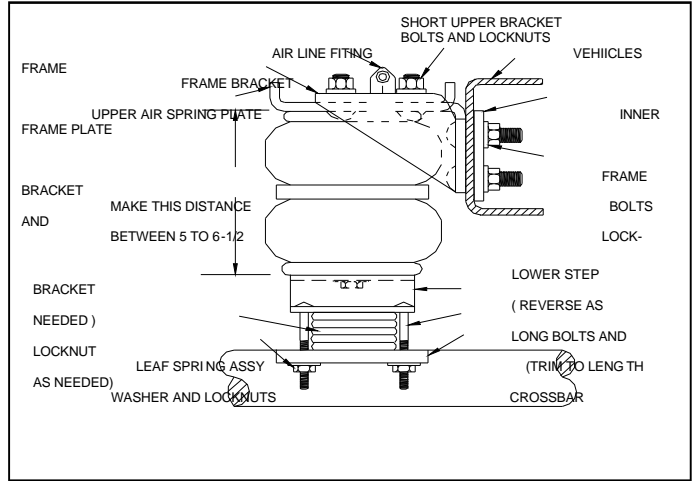

**FIG # 4 STANDARD MOUNTING STYLE
VIEW FROM REAR**

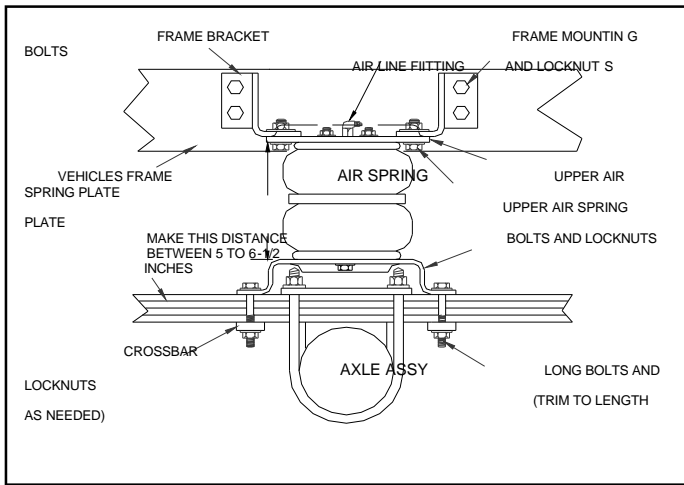

**FIG # 5 OPTIONAL MOUNTING STYLE
VIEW FROM TIRE SIDE**

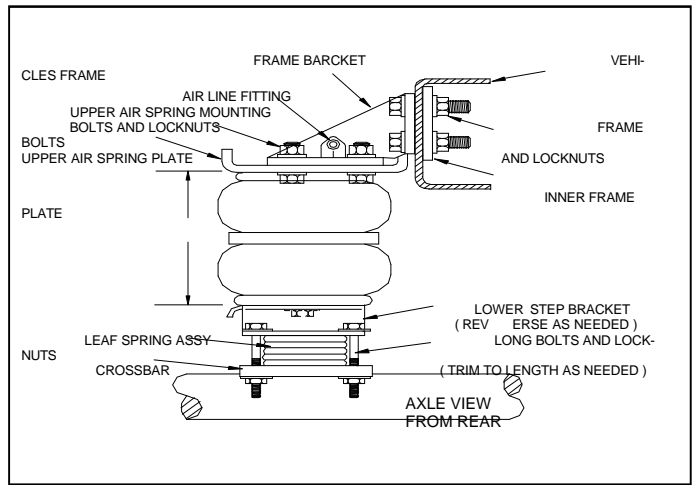

**FIG # 6 OPTIONAL MOUNTING STYLE
VIEW FROM REAR**

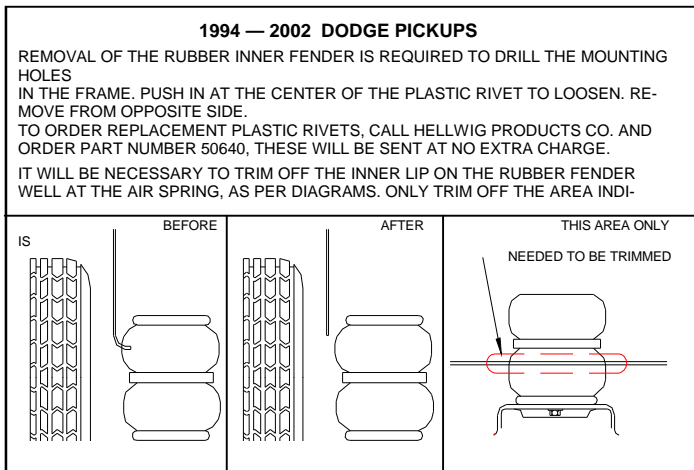

FIG # 7 FENDER WELL DETAIL

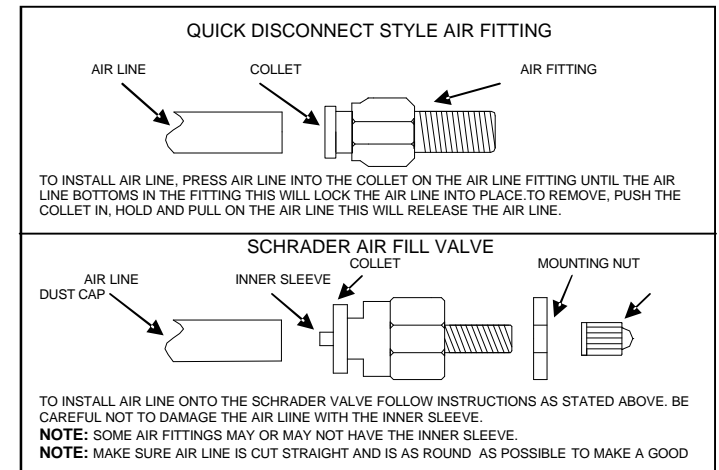

FIG # 8 HOSE END CONNECTION DETAIL

IMPORTANT NOTE

READ THIS INSTRUCTION AND WARNING SHEET COMPLETELY BEFORE STARTING YOUR INSTALLATION

A CLEARANCE OF SEVEN (7) INCHES IS REQUIRED BEWTEEN THE OUTSIDE OF THE VEHICLES FRAME AND THE INSIDE OF THE REAR TIRE, TO AVOID DAMAGE TO THE AIR SPRING AND TO THE TIRE DOUBLE CHECK THIS CLEARANCE NEEDED.

BEFORE INSTALLING SNOW CHAINS BE SURE TO CHECK FOR CLEARANCE AROUND THE AIR SPRING TO AVOID ANY DAMAGE.

WHEN LIFTING THE VEHICLE WITH A JACK, BE SURE TO SET THE PARKING BRAKE AND USE SAFETY STANDS, SUPPORT THE VEHI-
CLE BY THE AXLE TO KEEP THE SUSPENSION LOADED.

WHEN REINSTALLING THE TIRES, CHECK THE MANUFACTURERS SPECIFICATIONS FOR PROPER LUG NUT TORQUE.

MOVE ANY ELECTRICAL WIRES, FUEL LINES, BRAKE HOSES, OR OTHER OBJECTS INSIDE THE FRAME TO AVOID DAMAGE BEFORE DRILLING ANY HOLES ON THE FRAME.

THIS UNIT MUST BE SECURELY MOUNTED AT THE TOP AND BOT-
TOM OF THE AIR SPRING PRIOR TO INFLATION OR DAMAGE TO THE AIR SPRING WILL RESULT.

BE SURE THE FLAT PLATES INSIDE THE FRAME ARE PLACED BE-
HIND ANY LINES, WIRES, OR HOSES TO AVOID CRUSHING.

PROPER AIR SPRING SETUP HEIGHT IS BETWEEN FIVE (5) AND SIX
AND A HALF (6-1/2) INCHES, TOP AND BOTTOM OF AIR SPRING.



559-734-7451 800-367-5480 FAX 559-734-7460

**PARTS LIST
KIT # 6400**

PART #	QTY	DESCRIPTION
60102500	2	AIR BAG W/ 1/4"NPT PORT
20800269	2	SEE R&D BEFORE ORDERING
20801866	2	STEP BRACKET
20801867	2	RIGHT FRAME BRACKET
208001868	2	LEFT FRAME BRACKET
20801865	4	PLATE
20801863	8	CROSSBAR
125000999	1	AIR LINE BAG # 999
121900001	1	18' AIR BRAKE TUBING
121091879	2	AIR INFLATION VALVE
121901001	2	1/4" X 8' AIR LOOM
121500002	2	#4-1/4" MPT ELBOW
121050221	8	7" BLACK TIE STRAPS
125020399	1	SMALL PARTS BAG # BG-399
135006400	1	INSTRUCTIONS SHEET (R-6400)